



TRIDENT AUSTRALIA
FLUID SYSTEMS & COMPONENTS

Proudly Distributed By

Ruelco



LPO Line Pressure Operated Actuator Control System

Phone (504) 340-0055
Fax (504) 340-0056



Proudly Distributed By

TRIDENT AUSTRALIA
FLUID SYSTEMS & COMPONENTS

LPO

Line Pressure Operated Actuator Control System

FEATURES

- Space saving compact design
- Width of only 8" and overall height of 13"
- Rating of up to 6,000 psi.
- Completely self-contained
- Connected in three simple steps:
 - 1) 1/2" FNPT to flowline
 - 2) 3/8" tubing to actuator
 - 3) Bleed ports to reservoir

ACCESSORIES

One important feature of the Ruelco LPO is the optional scales feature available for the pressure switches. The scales allow the operator to properly set the trip point without having to rely on a secondary pressure gauge. (For reference only)

Another optional feature of the LPO system is the addition of Ruelco Tattletale Indicators. The Tattletale Indicator alerts the operator that the system has shut-in and can also indicate which pressure switch caused the shut-in. The Tattletale works by displaying a red indicating band and exhausting the system when the high or low pressure switch has been tripped.

Parts List for Line Pressure Operated System

| Item | Qty. | Description |
|------|------|---|
| A | 1 | MODEL 4HH2 HYDRAULIC PRESSURE SENSOR (HIGH) |
| B | 1 | MODEL 4HL2 HYDRAULIC PRESSURE SENSOR (LOW) |
| C | 1 | MODEL VC-2 VELOCITY CHECK VALVE |
| D | 1 | 8" MANIFOLD KIT ASSEMBLY |
| E | 1 | NEEDLE VALVE |
| F-1 | 1 | 3-WAY HYDRAULIC TATTLETALE ON LOW PILOT (OPTIONAL) |
| F-2 | 1 | 3-WAY HYDRAULIC TATTLETALE ON HIGH PILOT (OPTIONAL) |
| G | 2 | INDICATING SCALES (OPTIONAL) |

Assembly Shown With Optional Equipment F-1, F-2, and G

Consult Factory for Part Numbers and Pricing

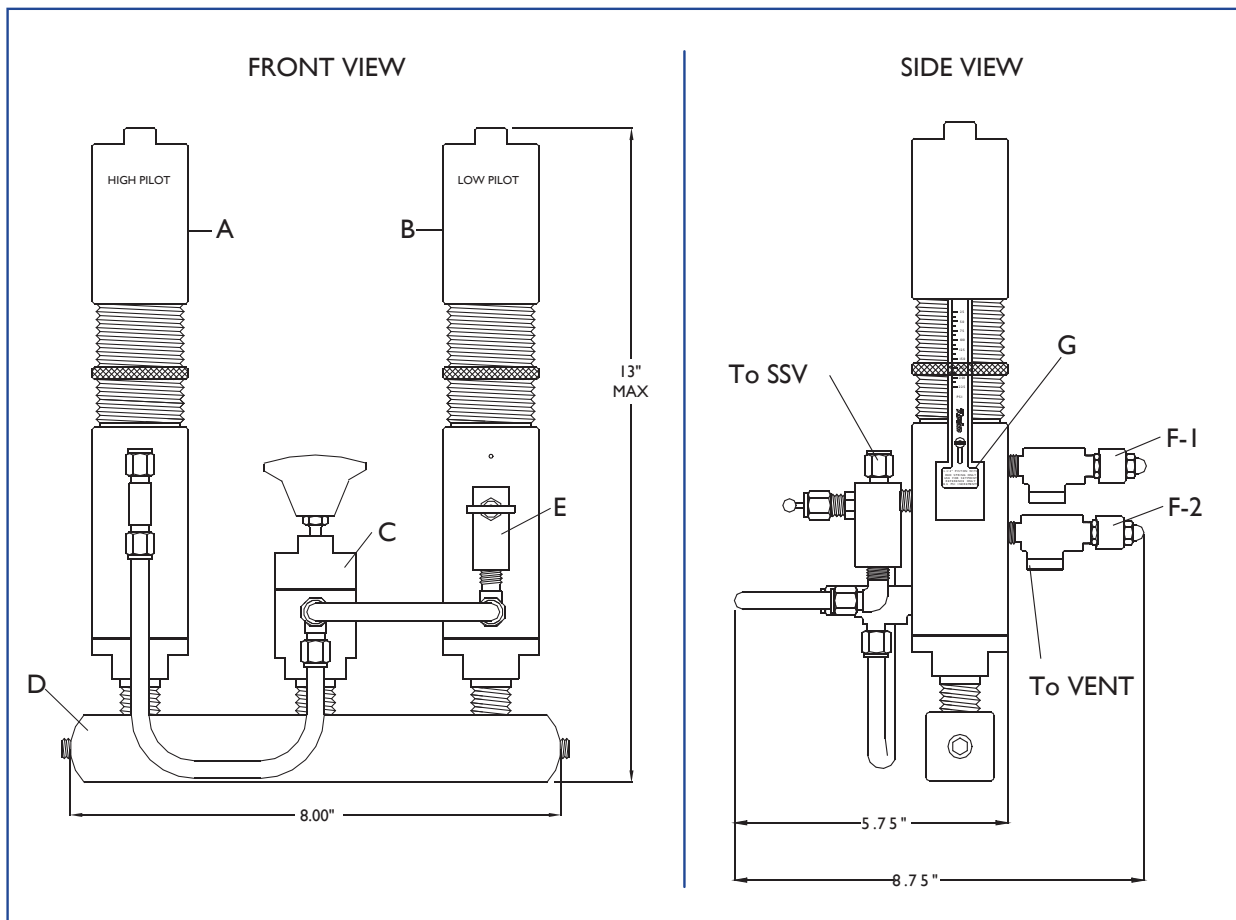

While this information is presented in good faith and believed to be accurate, Ruelco, Inc. does not guarantee satisfactory results from reliance upon such information. Nothing contained herein is to be construed as a warranty or guarantee, expressed or implied, regarding the performance, merchantability, and fitness with respect to the products. Ruelco, Inc. reserves the right, without notice, to alter or improve the designs or specifications of the products described herein.